

typical installations

When installing fuel units, to assure compliance with National Fire Protection Association's bulletin 3 "Installation of Oil Burning Equipment", fuel unit inlet pressures should not exceed 3 psig.

The systems illustrated show some of the ways to use the SPM supply pump units. They are not intended to be as more than suggestions.

It must be understood that we cannot and do not represent that these circuits will satisfy any particular local code requirements. Such compliance is the sole responsibility of the installing contractor.

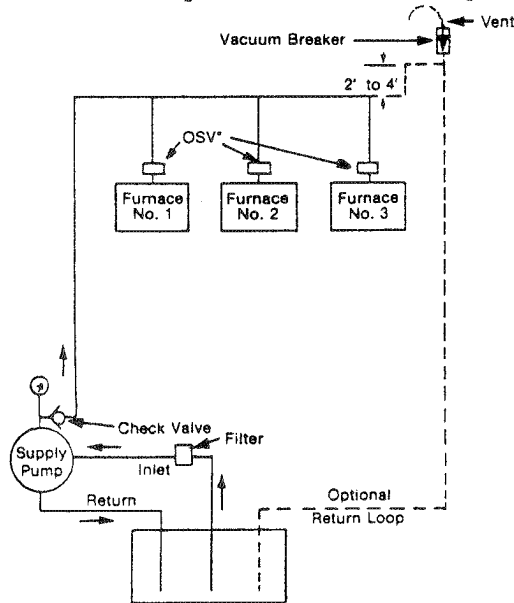

Suggested system for continuous pump operation with optional return loop.

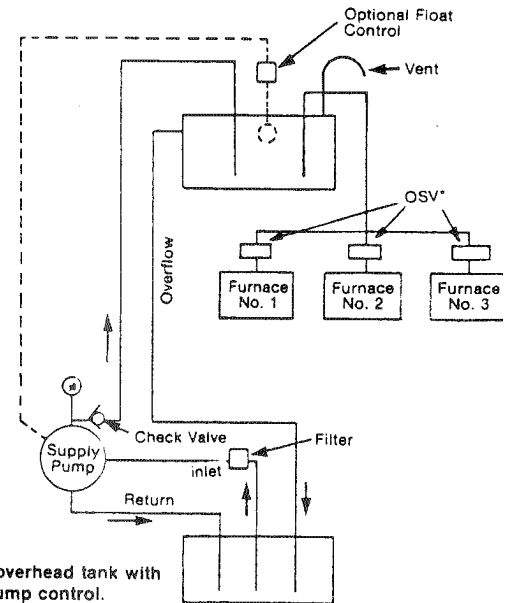

Suggested system for overhead tank with optional float switch pump control.

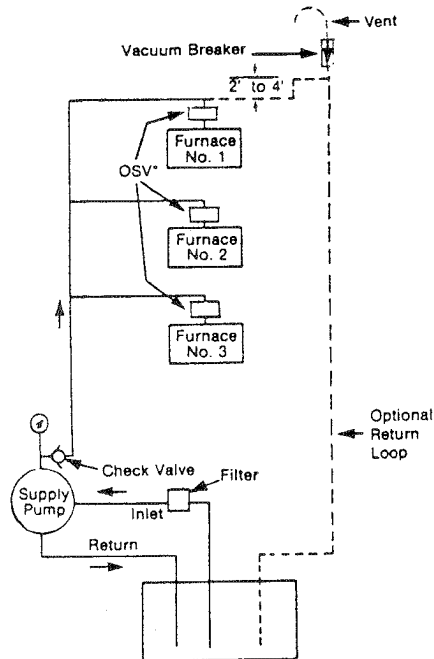

Suggested system for multi-level operation with optional return loop.

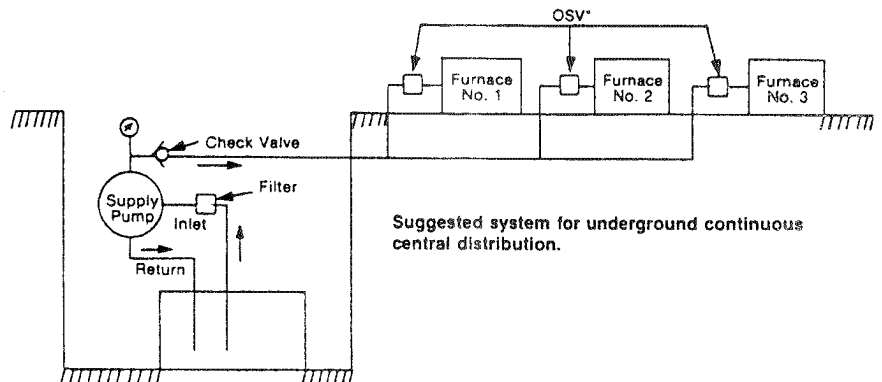

Suggested system for underground continuous central distribution.

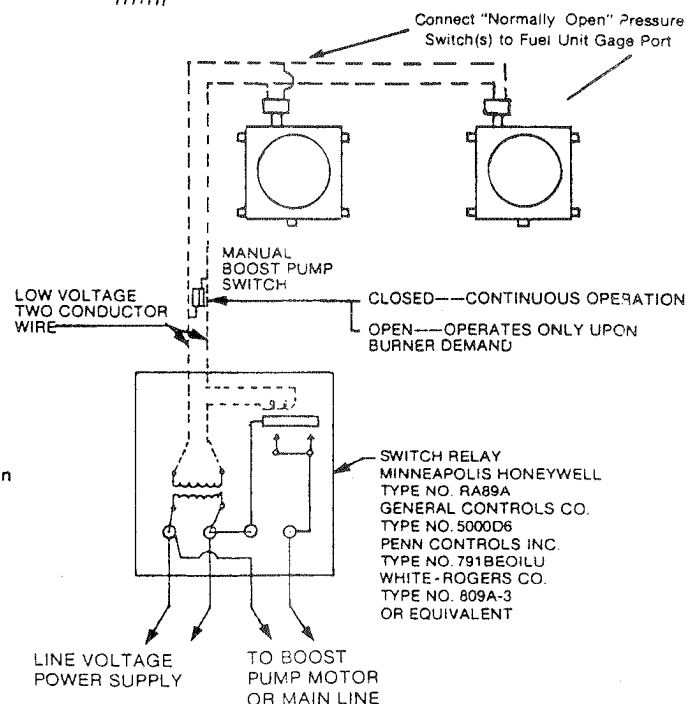

Wiring diagram for intermittent operation

*OSV
 Oil Safety Valve
 not furnished. Order
 one per appliance.